

TFE731-40AR

Honeywell



**LOWER OPERATING COSTS, INCREASED
PERFORMANCE AND IMPROVED MAINTAINABILITY.**

**Proven Turbofan
Propulsion Technology**

TFE731-40AR

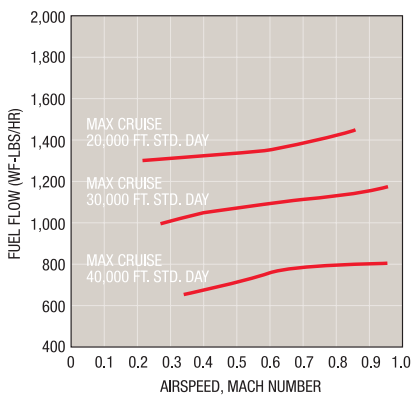
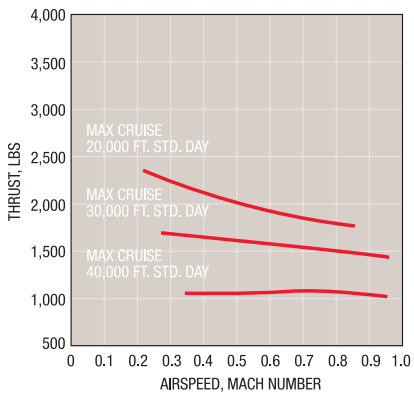
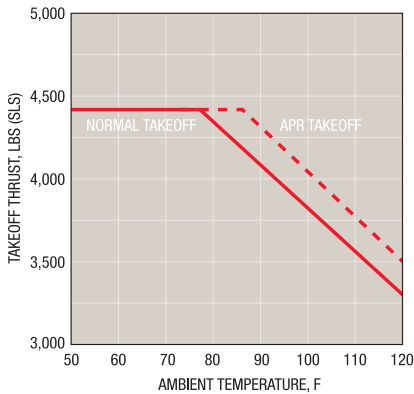

The TFE731-40AR is designed to meet operator requirements for lower operating costs, increased performance and improved durability/reliability and maintainability. In addition to improved core and LP spool component technologies, the TFE731-40AR includes 70 individual design and material enhancements. A new N1 Digital Electronic Engine Control (DEEC) with hydromechanical back-up, integral sync, and APR is also a standard feature

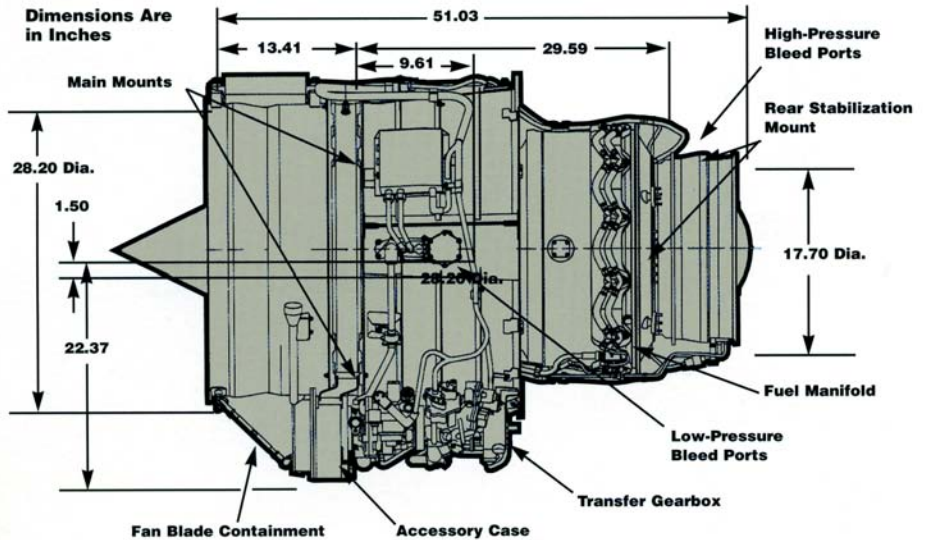

Performance

	Net Thrust	TSFC
Takeoff, Sea Level, Static (Available to 86° F)	4420 lb	0.460
Max Cruise, 40,000 ft, Mach 0.8 (ISA)	1040 lb	0.742

Design Data

Basic Engine Weight:	885 lb
Bypass Ratio:	2.9
Bleed Air Flow:	10% Core Flow (max)
Airflow:	146 lbs/sec
Service Ceiling:	51,000 ft
Airstart:	35,000 ft
Starting:	Electric
Accessory Power Extraction:	40 hp (max)

Find out more

To find out more about Honeywell's TFE731 family of engines please visit us online at www.honeywell.com/TFE731.

Honeywell Aerospace

1944 E. Sky Harbor Circle
Phoenix, AZ 85034
Tel: 1.800.601.3099
www.honeywell.com