

# Honeywell 36-150 Ported Shroud APU



HIGH PERFORMANCE. INCREASED SERVICE LIFE.

**Advanced APU Design  
for Custom Applications**

**Honeywell**

# 36-150 Ported Shroud Auxiliary Power Unit



## **Improving aircraft performance and reliability**

Featuring a high efficiency compressor and an innovative design, the 36-150 ported shroud Auxiliary Power Unit (APU) provides greater on-wing reliability and increased performance for improved main engine starting and enhanced high altitude electrical power capacity. The ported shroud design optimizes compressor use, providing not only higher pneumatic performance, but also higher shaft loads. Individual models are customized to optimize performance for specific applications, with up to 70lb/min of bleed airflow and up to 40kVA available in a range of combinations.

The enhanced performance of the ported shroud compressor allows the surge valve to be closed on the ground, creating an acoustic benefit (reduction of 10 dBA at the inlet). Aftermarket requirements and maintenance costs are reduced for the compressor section, as the ported shroud has no moving parts. These design enhancements deliver the highest power to weight ratio currently available in the marketplace, while also helping to lower your total cost of ownership.



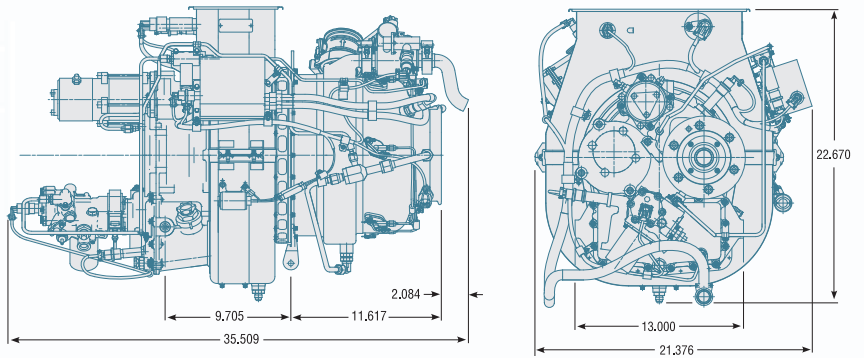
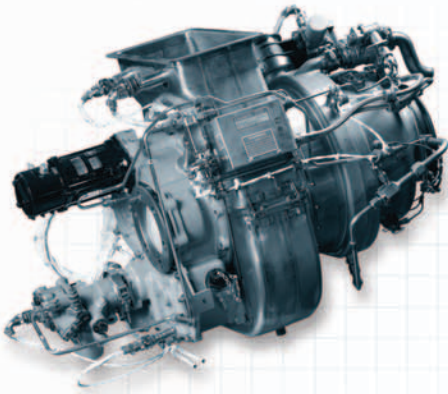

## Global Maintenance and Repair Services

Honeywell's comprehensive support network, spanning the Americas, Europe, Middle East, Africa, Asia and the South Pacific, delivers fully integrated service solutions and 24/7/365 support to meet the needs of the aerospace industry. As a world leader of aviation aftermarket services, Honeywell provides the knowledge and resources to take care of all your service needs – whenever and wherever you require maintenance and repair services.

- Integral bleed compressed air source
- Single-stage centrifugal compressor
- Ported compressor shroud
- Compressor rotor containment
- Turbine rotor containment
- Self-contained lubrication system
- Perforated inlet housing
- Single-stage radial turbine
- Effusion cooled combustor
- Exhaust eductor compartment cooling
- Digital controller with enhanced BITE features
- In-flight operable
- Automatic, unattended operation
- Automatic start cycle

## Key Performance Data

Weight:	125 – 168lbs
Digital Control Weight:	6lbs
Basic Spec:	FAA TSO-C77a Category 1 (Essential)
Rated Horsepower:	Up to 40kVA, 59F, SL
Bleed Airflow:	Up to 70lb/min, 59F, SL
Rated EGT:	1230F
Rotor Speed:	58,737 – 62,000 rpm

## Advantages of the 36-150 Ported Shroud APU

- High pneumatic and shaft load power density
- Wide operating range
- Superior reliability
- Substantial noise reduction
- Reduced cost of ownership.

## Why Honeywell?

- 50 years of auxiliary power experience
- An industry leader in APU integration
- Proven performance with over 70,000 delivered APUs
- Dedicated technology development resources
- State-of-the-art manufacturing, production and materials processes
- Global service and support network.

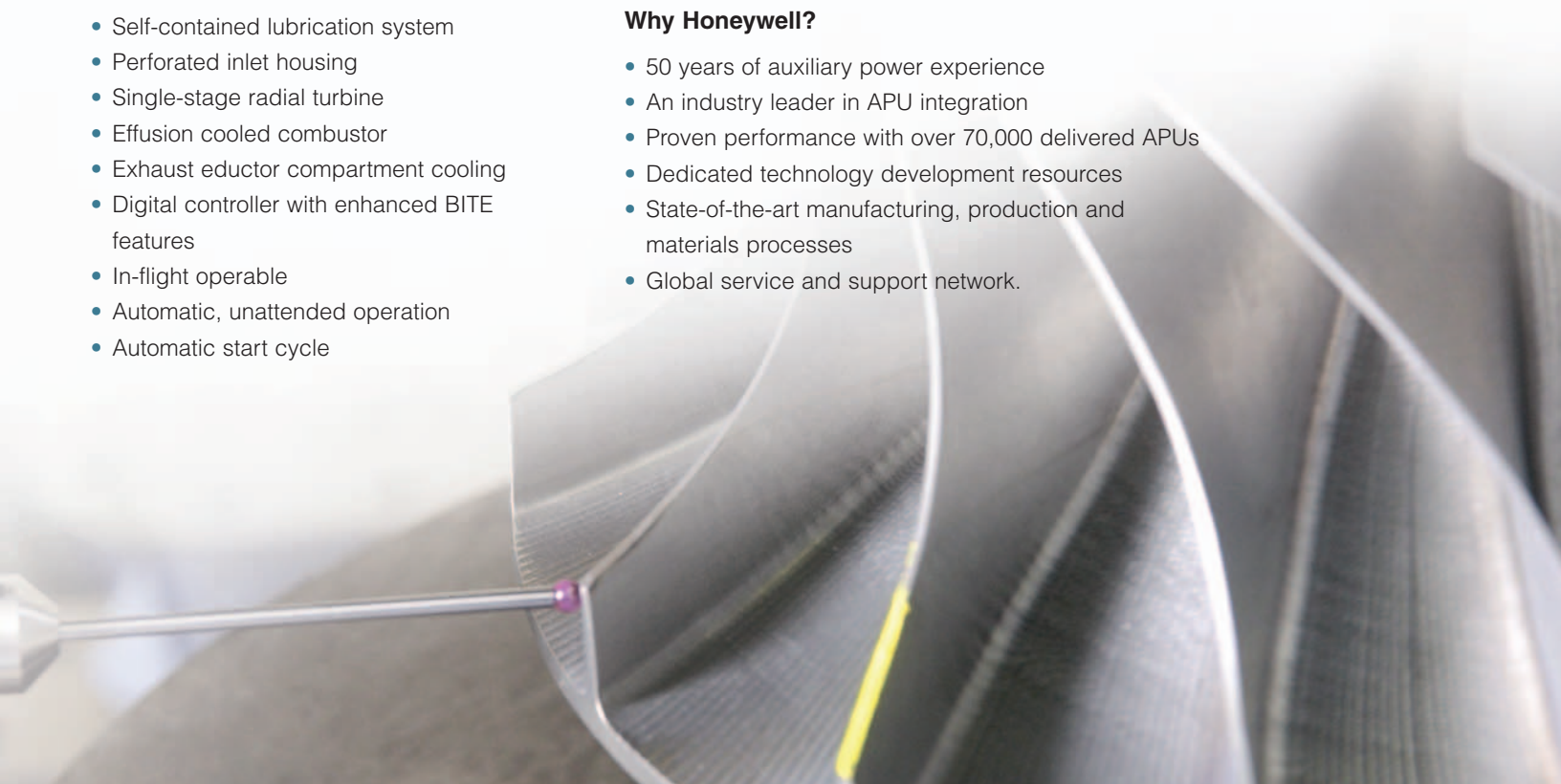

# At the forefront of technology leadership

## Honeywell Aerospace

Honeywell is a leading global provider of integrated avionics, engines, systems and service solutions for aircraft manufacturers, airlines, business and general aviation, military, space and airport operations. Honeywell remains at the forefront in the development of major new systems and technology leadership in the aerospace industry.

### Find out more

For more information on Honeywell's 36-150 APU, contact us at:  
1-800-601-3099 (US & Canada)  
1-602-365-3099 (International)  
1-602-365-3343 (Fax)  
[www.honeywellaerospace.com](http://www.honeywellaerospace.com)

### Honeywell

111 S. 34th Street  
Phoenix, Arizona 85034  
Telephone: (602) 365-3099  
Fax: (602) 365-3343  
[www.honeywell.com](http://www.honeywell.com)

## Global Facilities Network

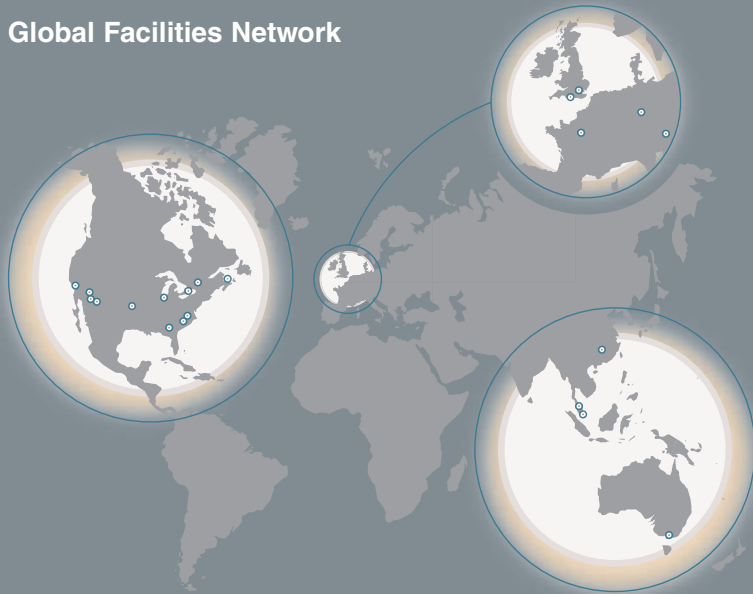

## Global Network of Support Services

Honeywell brings a global, comprehensive support network that delivers fully integrated service solutions to meet the needs of the aerospace industry. As a world leader of aviation aftermarket services, Honeywell provides the knowledge and resources to take care of all your service needs, whenever and wherever you require maintenance and repair services.

### North America

- Anniston, Alabama
- Greer, South Carolina
- Montreal, Canada
- Phoenix, Arizona
- Prince Edward Island, Canada
- Rocky Mount, North Carolina
- South Bend, Indiana
- Tempe, Arizona
- Toronto, Canada
- Torrance, California
- Tulsa, Oklahoma
- Tucson, Arizona

### Europe, Middle East, Africa, Asia and the South Pacific

- Bournemouth, United Kingdom
- Hlubocky-Marianske Udoli, Czech Republic
- Kuala Lumpur, Malaysia
- Luton, United Kingdom
- Melbourne, Australia
- Raunheim, Germany
- Singapore
- Vendôme, France
- Xiamen, People's Republic of China